

MODEL:HAER

單段1-Stage
比數：3,4,5,7,8,10

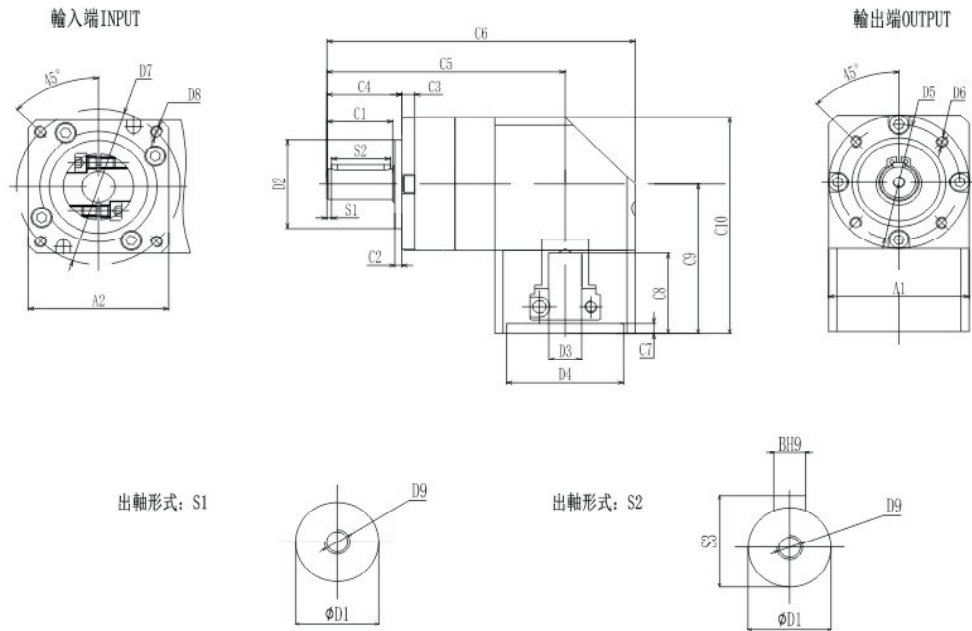

規格表 Specifications(Unit:mm):

尺寸/Size	HAER 060-L1	HAER 090-L1	HAER 120-L1	HAER 160-L1
D1	φ 14(16)	φ 20(22)	φ 25(32)	φ 40
D2	φ 40	φ 60	φ 80	φ 130
D3	φ 14(≤14)	φ 19(≤24)	φ 24(≤32)	φ 35(≤42)
D4	φ 50(30-50)	φ 70(30-70)	φ 110(50-145)	φ 114.3(70-180)
D5	φ 52	φ 70	φ 100	φ 145
D6	(4-M5X10)	(4-M6X12)	(4-M10X20)	(4-M12X24)
D7	φ 70(45-90)	φ 90(70-145)	φ 145(90-165)	φ 200(145-235)
D8	(4-M5X10)	(4-M6X12)	(4-M8X16)	(4-M12X24)
D9	M5*10	M6*12	M10*15	M16*20
C1	28	36	50	80
C2	3	3	4	5
C4	32	40	55	86
C5	(115.0)	(161.0)	(213.0)	(287.0)
C6	(145.0)	(194.0)	(273.0)	(367.0)
C7	(5.0)	(7.0)	(10.0)	(8.0)
C8	(36.5)	(45.5)	(73.0)	(94.0)
C9	(67.5)	(88.3)	(134.5)	(170.5)
C10	(97.6)	(140)	(194.5)	(252.5)
A1	60	90	120	165
A2	(60)	(90)	(120)	(178)
S1	2	3	5	7
S2	25	30	40	65
S3	16(18)	22.5(24.5)	28(35)	43
B	5	6	8	12

注1: ()括号内为可选择范围尺寸,()括号外为标准尺寸。
注2: 减速机出力轴可以为客户定制大小和长短。
注3: 输入尺寸可根据客户电机尺寸非标定制

Note 1: Inside of () is the optional range of sizes outside of () is the standard size s.
Note 2: The reducer output shaft size and length can be customized for customers.
Note 3: The input size can be customized according to the customer's motor size

MODEL:HAER

雙段2-Stage
比數：12,15,16,20,25,28,35,40,50,64,100

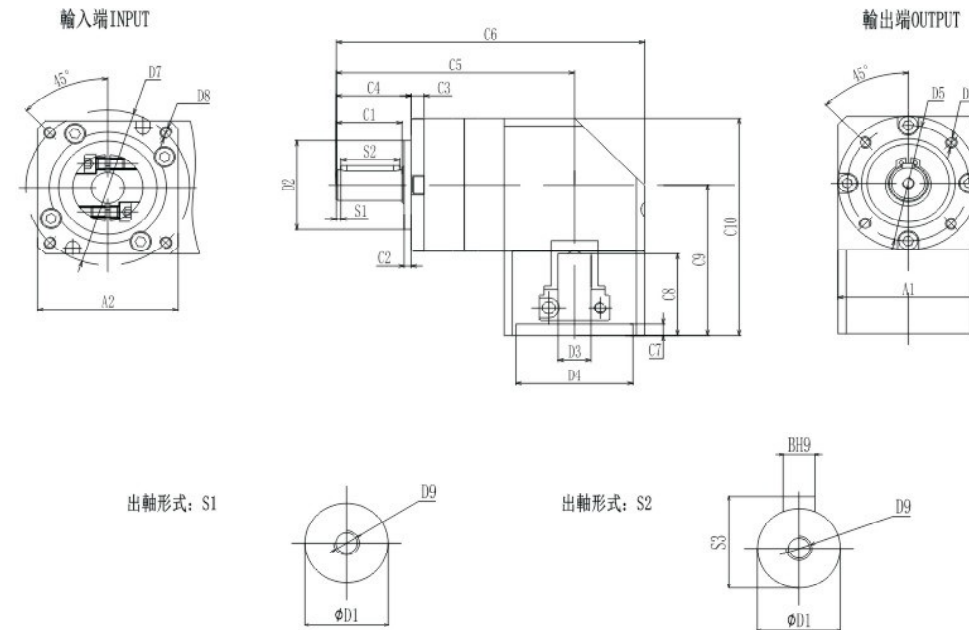

規格表 Specifications(Unit:mm):

尺寸/Size	HAER 060-L2	HAER 090-L2	HAER 120-L2	HAER 160-L2
D1	φ 14(16)	φ 20(22)	φ 25(32)	φ 40
D2	φ 40	φ 60	φ 80	φ 130
D3	φ 14(≤14)	φ 19(≤24)	φ 24(≤32)	φ 35(≤42)
D4	φ 50(30-50)	φ 70(30-70)	φ 110(50-145)	φ 114.3(70-180)
D5	φ 52	φ 70	φ 100	φ 145
D6	(4-M5X10)	(4-M6X12)	(4-M10X20)	(4-M12X24)
D7	φ 70(45-90)	φ 90(70-145)	φ 145(90-165)	φ 200(145-235)
D8	(4-M5X10)	(4-M6X12)	(4-M8X16)	(4-M12X24)
D9	M5*10	M6*12	M10*15	M16*20
C1	28	36	50	80
C2	3	3	4	5
C4	32	40	55	86
C5	(132.0)	(185.0)	(245.0)	(334.0)
C6	(162.0)	(219.0)	(305.0)	(414.0)
C7	(5.0)	(7.0)	(10.0)	(8.0)
C8	(36.5)	(45.5)	(73.0)	(94.0)
C9	(67.5)	(88.3)	(134.5)	(170.5)
C10	(97.6)	(140)	(194.5)	(252.5)
A1	60	90	120	165
A2	(60)	(90)	(120)	(178)
S1	2	3	5	7
S2	25	30	40	65
S3	16(18)	22.5(24.5)	28(35)	43
B	5	6	8	12

注1: ()括号内为可选择范围尺寸,()括号外为标准尺寸。
注2: 减速机出力轴可以为客户定制大小和长短。
注3: 输入尺寸可根据客户电机尺寸非标定制

Note 1: Inside of () is the optional range of sizes outside of () is the standard size s.
Note 2: The reducer output shaft size and length can be customized for customers.
Note 3: The input size can be customized according to the customer's motor size